

HARMONIA SERIES

Double toilet roll holder with shelf



AI2006B
Black finish



AI2006C
Bright finish



AI2006CS
Satin finish

General Description

- Toilet roll holder with flat shelf to hold mobile phones, watches, air-fresheners, keys or other small objects, made of AISI 304 stainless steel, from Mediclinics' Harmonia series.
- With a modern and intelligent design, this bathroom toilet roll holder has two arms for two separate rolls of toilet paper, each with a stopper at the end to prevent the toilet roll from falling off during use.
- This toilet roll holder is one of the ideal bathroom accessories to install in your home, and can it also be used in public-use bathrooms, such as hotels, bars, restaurants, offices, etc.
- Made with high-quality, durable and anti-corrosive materials.
- Suitable for most sizes of household toilet rolls.
- Includes stainless steel hardware for installation on brick walls.

Components and Materials

- **AI2006B:** double toilet roll holder with shelf made of AISI 304 stainless steel black finish.
- **AI2006C:** double toilet roll holder with shelf made of AISI 304 stainless steel bright finish.
- **AI2006CS:** double toilet roll holder with shelf made of AISI 304 stainless steel satin finish.
- **PAPER ROLL AXIS:** made of AISI 304 stainless steel. Designed with an end stopper to prevent the roll of paper from falling out during the operation. Fixed to the wall bracket through welding.
- **WALL-SHELF BRACKET:** of one-piece 90° bent, made of 1.5 mm thick AISI 304 stainless steel sheet. The shelf has a 45° fold at its end to avoid falling objects deposited on it.

Technical Specifications

Dimensions	270 x 95 x 103 mm
Wall-shelf bracket thickness	1.5 mm
Net weight	640 g

Dimensions

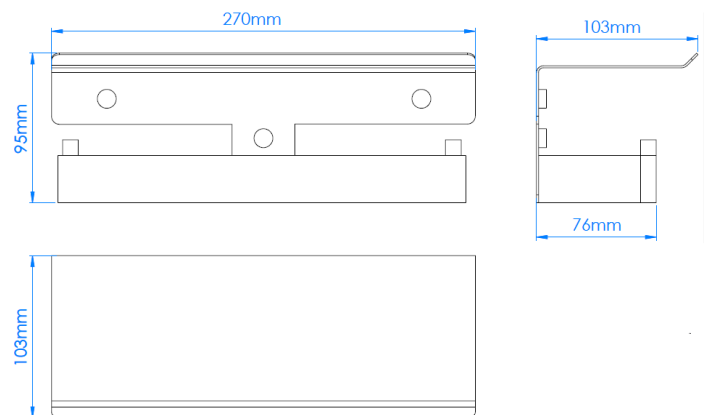

Dimensions: ± 4%